

Customer / Project: Vms recon	Project No. 17976	Date / Time: 17/2-15
Type of turbocharger R 251 Gas outlet	Test Number	Engineer: JKH

Ultrasonic wall thickness measurement of the Casings

Gas Inlet Casing			Gas Outlet Casing		
Position	Thickness	Remarks	Position	Thickness	Remarks
1			1	9,2mm	
2			2	9,6mm	
3			3	8,2mm	
4			4	8,3mm	
5			5	7,6mm	
6			6	11,2mm	

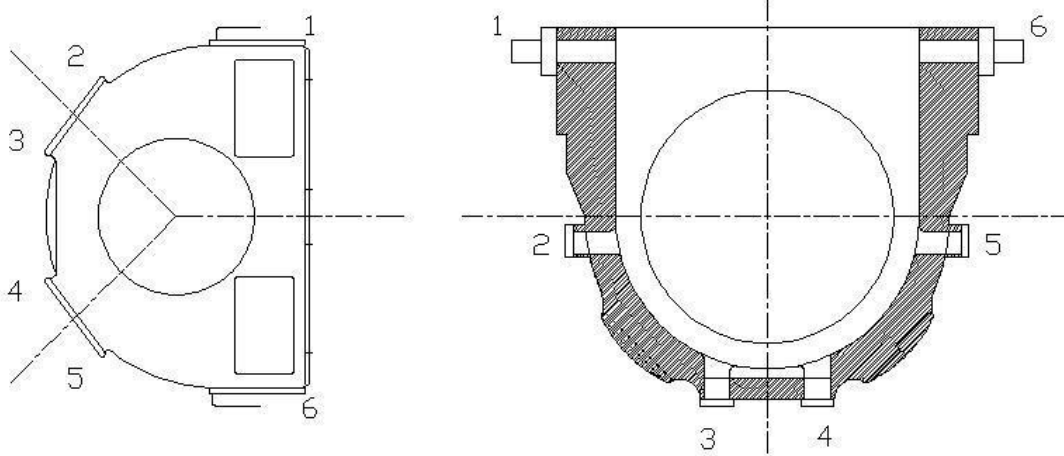

Hydrostatic Test Report

Bore Gas Inlet Casing	Gas Inlet Casing Hydrostatic Test 6 Bar	Gas Outlet Casing Hydrostatic Test 6 Bar
Measured	Remarks	Remarks ok
New		

Measurement tools: M273

Date: 17/2-15

Place: Fr. Havn

Engineer: Jesper Høyer