

Installation (ship): Recon Use: Stock Project no.: _____
 Engine type: M32 Engine no.: _____ Engine running hours: _____

Cylinder liner – MaK M32

Meas. point I , II , III , IIII I = 95 II = 200 III = 450 IV = 580 mm

Measured: Mounted
 Free

Engine equipped with antipolishing ring (APR): Yes
 No

Nominal diameter = 320. – 320.057 mm

Wear limits: I = 321.00mm, II = 321.00 mm, III, IV = 321.00mm

Ovality = 0.30 mm
 (Difference between d_{max} and d_{min} measured on any level).

Reference diameter (or level IV / position 3): _____

Antipolishing ring instructions

1. Inspect the antipolishing ring at every piston overhaul.
2. Turn the antipolishing ring upside down at the first piston overhaul.
3. Change the antipolishing at every second piston overhaul.

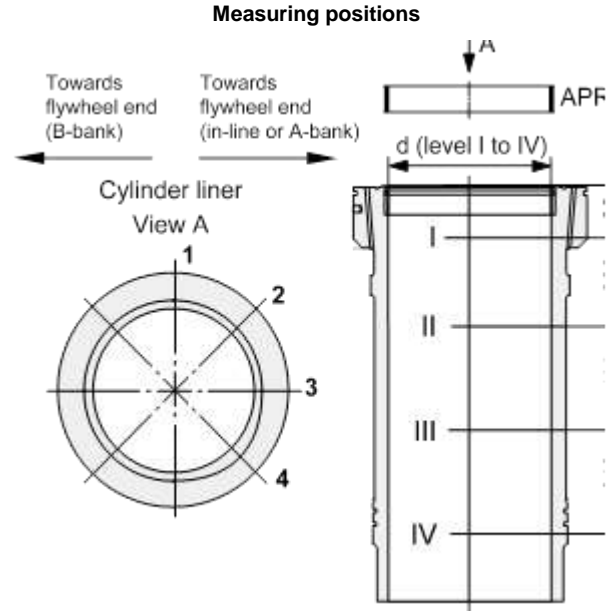

Bank	Cylinder number								
	1	2	3	4	5	6	7	8	9
Cylinder liner diameter d (deviation in 1/100 mm)									
I	1			320,17					
	2			320,17					
	3			320,18					
	4			320,18					
II	1			320,24					
	2			320,24					
	3			320,25					
	4			320,25					
III	1			320,26					
	2			320,27					
	3			320,27					
	4			320,26					
IV	1			320,28					
	2			320,28					
	3			320,28					
	4			320,28					
Remarks / Manufactor no.:									

Measuring tool number: _____

Date of measurement: 30.04.2015 Place: Frederikshavn

Name: Kim Kokholm